

Type 6008

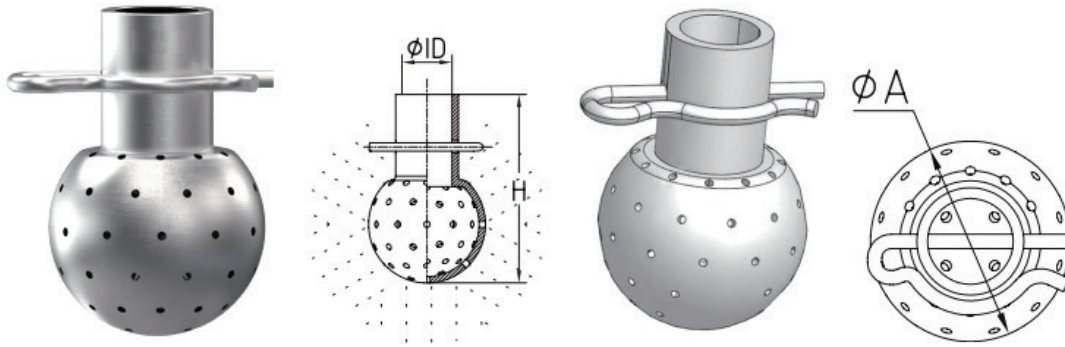

STANDARD SIZE/*At temperature 50°C

360° Pattern

| CODE | Connection | DIN11850/ DIN11866 | | | Operating Dia | P.R. | Flow rate (m ³ /h) | Ball dia | H |
|---------|-------------|--------------------|-----------|------|---------------|------|-------------------------------|----------|----|
| | | DIN | ISO1127 | Inch | | | | | |
| 6008001 | Slip on | 12/13 | 13.5 | 1/2" | 0.8-1.5 | 2.8 | - | 28 | 45 |
| 6008002 | Slip on | 18/19 | 17.2/21.3 | 3/4" | 1.0-2.0 | 5.1 | - | 28 | 45 |
| 6008003 | G BSP G1/4" | 13 | 13.5 | 1/2" | 0.8-1.5 | 2.4 | - | 28 | 45 |
| 6008004 | G BSP G1/2" | 19 | 17.2/21.3 | 3/4" | 1.0-2.0 | 4.7 | - | 28 | 45 |

The welded type is similar to slip on, only 316L is available. Hole ϕ 1.25mm

| CODE | Connection | DIN11850/ DIN11866 | | | Operating Dia | P.R. | Flow rate (m ³ /h) | Ball dia | H |
|---------|-------------|--------------------|---------|------|---------------|------|-------------------------------|----------|----|
| | | DIN | ISO1127 | Inch | | | | | |
| 6008005 | Slip on | 28/29 | 26.9 | 1" | 2.0-3.0 | 9.8 | 15.3 | 64 | 85 |
| 6008006 | Slip on | 40/41 | 33.7 | 1/2" | 2.5-3.5 | 12.8 | 20.8 | 64 | 85 |
| 6008007 | G BSP G3/4" | 29 | 26.9 | 1" | 2.0-3.0 | 9.4 | 14.7 | 64 | 85 |
| 6008008 | G BSP G1" | 41 | 33.7 | 1/2" | 2.5-3.5 | 12.3 | 20.2 | 64 | 85 |

The welded type is similar to slip on, only 316L is available. Hole ϕ 2.00mm

| CODE | Connection | DIN11850/ DIN11866 | | | Operating Dia | P.R. | Flow rate (m ³ /h) | Ball dia | H |
|---------|---------------|--------------------|---------|------|---------------|------|-------------------------------|----------|-----|
| | | DIN | ISO1127 | Inch | | | | | |
| 6008009 | Slip on | 52/53 | - | 2" | 3.5-5.0 | 28.4 | 47.00 | 93 | 115 |
| 6008010 | Slip on | 52/53 | - | 2" | 4.0-6.0 | 35.6 | 58.90 | 93 | 115 |
| 6008011 | G BSP G1 1/2" | 53 | - | 2" | 3.5-5.0 | 27.4 | 45.37 | 93 | 115 |
| 6008012 | G BSP G1 1/2" | 53 | - | 2" | 4.0-6.0 | 34.5 | 57.13 | 93 | 115 |

The welded type is similar to slip on, only 316L is available. Hole ϕ 2.00mm, Hole ϕ 2.40mm

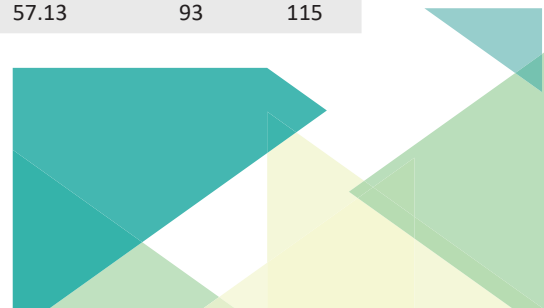

Type 6008

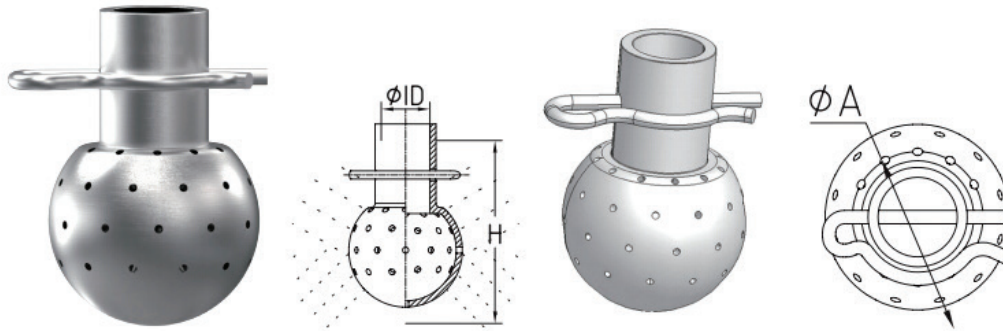

STANDARD SIZE/*At temperature 50°C

270° Upward Spray

| CODE | Connection | DIN11850/ DIN11866 | | | Operating Dia | P.R. | Flow rate (m ³ /h) | | Ball dia | H |
|---------|-------------|--------------------|-----------|------|---------------|------|-------------------------------|------|----------|---|
| | | DIN | ISO1127 | Inch | | | Meters(m) | 1Bar | | |
| 6008013 | Slip on | 12/13 | 13.5 | 1/2" | 0.8-1.5 | 2.6 | - | 28 | 45 | |
| 6008014 | Slip on | 18/19 | 17.2/21.3 | 3/4" | 1.0-2.0 | 4.6 | - | 28 | 45 | |
| 6008015 | G BSP G1/4" | 13 | 13.5 | 1/2" | 0.8-1.5 | 2.2 | - | 28 | 45 | |
| 6008016 | G BSP G1/2" | 19 | 17.2/21.3 | 3/4" | 1.0-2.0 | 4.3 | - | 28 | 45 | |

The welded type is similar to slip on, only 316L is available. Hole ϕ 1.25mm

| CODE | Connection | DIN11850/ DIN11866 | | | Operating Dia | P.R. | Flow rate (m ³ /h) | | Ball dia | H |
|---------|-------------|--------------------|---------|------|---------------|------|-------------------------------|------|----------|---|
| | | DIN | ISO1127 | Inch | | | Meters(m) | 1Bar | | |
| 6008017 | Slip on | 28/29 | 26.9 | 1" | 2.0-3.0 | 8.9 | 13.9 | 64 | 85 | |
| 6008018 | Slip on | 40/41 | 33.7 | 1/2" | 2.5-3.5 | 11.6 | 18.9 | 64 | 85 | |
| 6008019 | G BSP G3/4" | 29 | 26.9 | 1" | 2.0-3.0 | 8.5 | 13.3 | 64 | 85 | |
| 6008020 | G BSP G1" | 41 | 33.7 | 1/2" | 2.5-3.5 | 11.2 | 18.3 | 64 | 85 | |

The welded type is similar to slip on, only 316L is available. Hole ϕ 2.00mm

| CODE | Connection | DIN11850/ DIN11866 | | | Operating Dia | P.R. | Flow rate (m ³ /h) | | Ball dia | H |
|---------|---------------|--------------------|---------|------|---------------|------|-------------------------------|------|----------|---|
| | | DIN | ISO1127 | Inch | | | Meters(m) | 1Bar | | |
| 6008021 | Slip on | 52/53 | - | 2" | 3.5-5.0 | 25.8 | 42.7 | 93 | 115 | |
| 6008022 | Slip on | 52/53 | - | 2" | 4.0-6.0 | 32.3 | 53.5 | 93 | 115 | |
| 6008023 | G BSP G1 1/2" | 53 | - | 2" | 3.5-5.0 | 24.9 | 41.2 | 93 | 115 | |
| 6008024 | G BSP G1 1/2" | 53 | - | 2" | 4.0-6.0 | 31.3 | 51.9 | 93 | 115 | |

The welded type is similar to slip on, only 316L is available. Hole ϕ 2.00mm, Hole ϕ 2.40mm

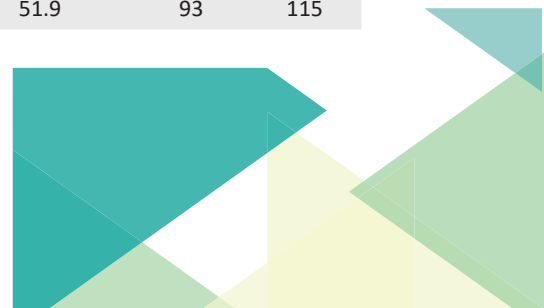

Type 6008

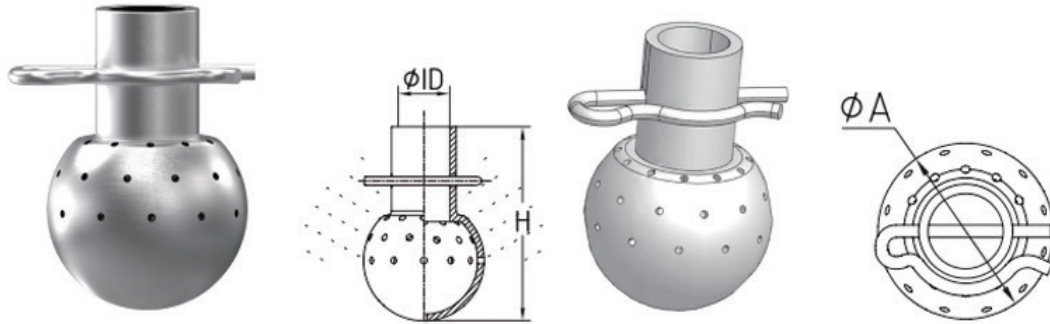

STANDARD SIZE/*At temperature 50°C

180° Upward Spray

| CODE | Connection | DIN11850/ DIN11866 | | | Operating Dia | P.R. | Flow rate (m ³ /h) | Ball dia | H |
|---------|-------------|--------------------|-----------|------|---------------|------|-------------------------------|----------|----|
| | | DIN | ISO1127 | Inch | | | | | |
| 6008025 | Slip on | 12/13 | 13.5 | 1/2" | 0.8-1.5 | 1.43 | - | 28 | 45 |
| 6008026 | Slip on | 18/19 | 17.2/21.3 | 3/4" | 1.0-2.0 | 2.6 | - | 28 | 45 |
| 6008027 | G BSP G1/4" | 13 | 13.5 | 1/2" | 0.8-1.5 | 1.2 | - | 28 | 45 |
| 6008028 | G BSP G1/2" | 19 | 17.2/21.3 | 3/4" | 1.0-2.0 | 2.4 | - | 28 | 45 |

The welded type is similar to slip on, only 316L is available. Hole ϕ 1.25mm

| CODE | Connection | DIN11850/ DIN11866 | | | Operating Dia | P.R. | Flow rate (m ³ /h) | Ball dia | H |
|---------|-------------|--------------------|---------|------|---------------|------|-------------------------------|----------|----|
| | | DIN | ISO1127 | Inch | | | | | |
| 6008029 | Slip on | 28/29 | 26.9 | 1" | 2.0-3.0 | 7.8 | 12.4 | 64 | 85 |
| 6008030 | Slip on | 40/41 | 33.7 | 1/2" | 2.5-3.5 | 8.3 | 14.1 | 64 | 85 |
| 6008031 | G BSP G3/4" | 29 | 26.9 | 1" | 2.0-3.0 | 7.5 | 11.6 | 64 | 85 |
| 6008032 | G BSP G1" | 41 | 33.7 | 1/2" | 2.5-3.5 | 7.9 | 13.7 | 64 | 85 |

The welded type is similar to slip on, only 316L is available. Hole ϕ 2.00mm

| CODE | Connection | DIN11850/ DIN11866 | | | Operating Dia | P.R. | Flow rate (m ³ /h) | Ball dia | H |
|---------|-------------|--------------------|---------|------|---------------|------|-------------------------------|----------|-----|
| | | DIN | ISO1127 | Inch | | | | | |
| 6008033 | Slip on | 52/53 | - | 2" | 3.5-5.0 | 19.3 | 30.6 | 93 | 115 |
| 6008034 | Slip on | 52/53 | - | 2" | 4.0-6.0 | 22.5 | 37.5 | 93 | 115 |
| 6008035 | G BSP G3/4" | 53 | - | 2" | 3.5-5.0 | 18.6 | 29.6 | 93 | 115 |
| 6008036 | G BSP G1" | 53 | - | 2" | 4.0-6.0 | 21.9 | 36.4 | 93 | 115 |

The welded type is similar to slip on, only 316L is available. Hole ϕ 2.00mm, Hole ϕ 2.40mm

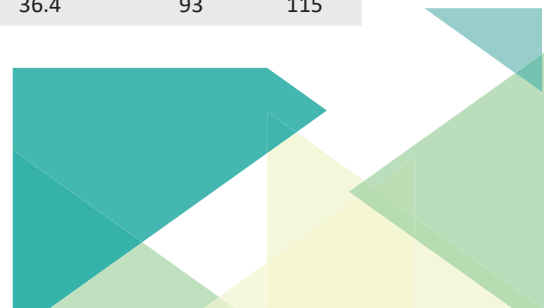

Type 6008

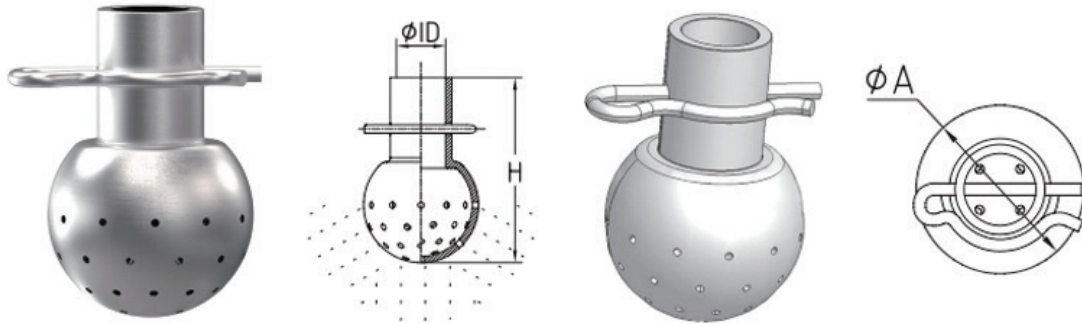

STANDARD SIZE/*At temperature 50°C

180° Downward Spray

| CODE | Connection | DIN11850/ DIN11866 | | | Operating Dia | P.R. | Flow rate (m ³ /h) | Ball dia | H |
|---------|-------------|--------------------|-----------|------|---------------|------|-------------------------------|----------|----|
| | | DIN | ISO1127 | Inch | | | | | |
| 6008037 | Slip on | 12/13 | 13.5 | 1/2" | 0.8-1.5 | 1.7 | - | 28 | 45 |
| 6008038 | Slip on | 18/19 | 17.2/21.3 | 3/4" | 1.0-2.0 | 3.1 | - | 28 | 45 |
| 6008039 | G BSP G1/4" | 13 | 13.5 | 1/2" | 0.8-1.5 | 1.5 | - | 28 | 45 |
| 6008040 | G BSP G1/2" | 19 | 17.2/21.3 | 3/4" | 1.0-2.0 | 2.8 | - | 28 | 45 |

The welded type is similar to slip on, only 316L is available. Hole ϕ 1.25mm

| CODE | Connection | DIN11850/ DIN11866 | | | Operating Dia | P.R. | Flow rate (m ³ /h) | Ball dia | H |
|---------|-------------|--------------------|---------|------|---------------|------|-------------------------------|----------|----|
| | | DIN | ISO1127 | Inch | | | | | |
| 6008041 | Slip on | 28/29 | 26.9 | 1" | 2.0-3.0 | 6.9 | 10.9 | 64 | 85 |
| 6008042 | Slip on | 40/41 | 33.7 | 1/2" | 2.5-3.5 | 7.8 | 12.8 | 64 | 85 |
| 6008043 | G BSP G3/4" | 29 | 26.9 | 1" | 2.0-3.0 | 6.6 | 10.5 | 64 | 85 |
| 6008044 | G BSP G1" | 41 | 33.7 | 1/2" | 2.5-3.5 | 7.5 | 12.4 | 64 | 85 |

The welded type is similar to slip on, only 316L is available. Hole ϕ 2.00mm

| CODE | Connection | DIN11850/ DIN11866 | | | Operating Dia | P.R. | Flow rate (m ³ /h) | Ball dia | H |
|---------|---------------|--------------------|---------|------|---------------|------|-------------------------------|----------|-----|
| | | DIN | ISO1127 | Inch | | | | | |
| 6008045 | Slip on | 52/53 | - | 2" | 3.5-5.0 | 17.1 | 28.9 | 93 | 115 |
| 6008046 | Slip on | 52/53 | - | 2" | 4.0-6.0 | 22.4 | 37.1 | 93 | 115 |
| 6008047 | G BSP G1 1/2" | 53 | - | 2" | 3.5-5.0 | 16.6 | 27.9 | 93 | 115 |
| 6008048 | G BSP G1 1/2" | 53 | - | 2" | 4.0-6.0 | 21.7 | 35.6 | 93 | 115 |

The welded type is similar to slip on, only 316L is available. Hole ϕ 2.00mm, Hole ϕ 2.40mm